



오늘 가정 화재 대피 계획을 세워요.



• ㉞

- ㉞
- ㉞
- ㉞
- ㉞
- ㉞

㉞ ㉞

- ㉞
- ㉞
- ㉞
- ㉞

㉞ ㉞

- ㉞
- ㉞
- ㉞
- ㉞
- ㉞
- ㉞
- ㉞
- ㉞

㉞

- ㉞
- ㉞
- ㉞

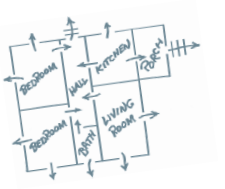

㉞ ㉞

- ㉞
- ㉞
- ㉞
- ㉞

> ㉞

- ㉞
- ㉞
- ㉞
- ㉞
- ㉞
- ㉞

㉞ ㉞

- ㉞
- ㉞
- ㉞
- ㉞





Fire Escape Plan

가정 화재 안전 점검

가급적 모든 방에서 두 개의 통로를 보여주는 집 평면도를 작성하세요.

가정 화재 대피 계획을 기억하고 실습을 상기할 수 있도록 냉장고나 청결한 장소에 가정 화재 대피 계획을 게시합니다.

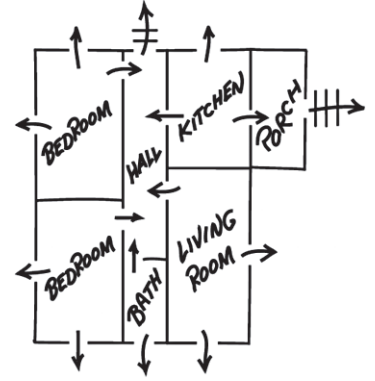

Large grid area for drawing the floor plan.