



The City of London
Arva Pumping Station to Huron Street Transmission Main
Municipal Class Environmental Assessment Master Plan

NOTICE OF PUBLIC INFORMATION CENTRE

Background

The City of London (City) has initiated a Municipal Class Environmental Assessment (MCEA) master plan study to develop short and long-term maintenance and improvement/expansion plans for the Arva Huron Transmission Watermain between the Arva Pumping Station and Huron Street (See Map on Back). This study includes an assessment of the potential need to maintain and/or widen the existing transmission main easement to continue ongoing monitoring of the condition of the watermain and/or for potential maintenance, repair or replacement of the existing watermain. Long term considerations include evaluating alternative options for routing the watermain between the Arva Pumping Station and Huron Street in total or for specific sections for improvement or expansion purposes. The routing options to be investigated will address long-term transmission capacity needs and provide for water system redundancy.

The MCEA study is being completed in accordance with the Ontario Environmental Assessment Act and is following Approach #2 of the Municipal Engineers Association Municipal Class EA (as amended in 2015) process, fulfilling the requirements for Schedule B projects, including public and stakeholder consultation.

How to Get Involved

The City of London wants anyone with an interest in the study to have an opportunity to provide input, which will help the project team in the decision-making process.

In order to comply with social distancing requirements for COVID-19 the City will be holding a Virtual Online Public Information Centre (PIC) Scheduled for:

Date: Wednesday November 25th, 2020

Time: 6:00 PM to 8:00 PM

Format: Zoom Webinar Presentation followed by a question period

The PIC will present an overview of the project including existing conditions, the need for improvements, potential alternative solutions, preferred short and long term strategies including any potential water infrastructure projects and next steps in the study.

To register for this PIC please send an email to: Paul.adams2@aecom.com.

The presentation and material presented during this online PIC will also be made available in a virtual format on the City of London Project Webpage:

<https://london.ca/projects/arva-pumping-station-huron-street-water-transmission-main-master-plan>

For more information or if you want to be placed on our mailing list for updates, please contact us at:

Stephen Romano, P.Eng

Project Manager
Corporation of the City of London
300 Dufferin Avenue
London ON, N6A 4L9
Tel: 519-661-2489 x5537
Email: sromano@london.ca

John Haasen, PMP, CET

Project Director,
AECOM Canada Ltd.
250 York Street, Suite 410
London ON, N6A 6K2
Tel: 519-963-5889
Email: john.haasen@aecom.com

With the exception of personal information, all comments will become part of the public record of the study. The study is being conducted according to the requirements of the Municipal Class Environmental Assessment, which is a planning process approved under Ontario's Environmental Assessment Act. Issued on November 9th, 2020



WELCOME

City of London: Arva Pumping Station to Huron Street Water Transmission Main



Municipal Class Environmental Assessment Master Plan Public Information Centre (PIC)

We will begin shortly. This is a webinar platform, which allows you to see and hear the presenters, but we cannot see or hear you.

For your convenience, you will find a Q&A window on the screen where you can type in a question at any time. We will address questions at the end of the presentation.

November 25, 2020



Housekeeping

- Speaker video will be turned off for the majority of the presentation
- Attendees will be muted; please participate through the Q&A window
- If you have any technological issues, please also use the Q&A window
- Town Hall is being recorded and will be posted on the Project Website following the meeting

Town Hall Agenda

6:00 – 8:00 pm

1. Introductions and Purpose
2. Presentation - Approximately 45 minutes
3. Questions and Answers (use the Q&A window to type in a question)



Project Team Introductions



Stephen Romano
City of London
Water Engineering Project
Manager



Aaron Rozentals
City of London
Division Manager, Water
Engineering



John Haasen
AECOM
Senior Vice President, Project Manager
and Town Hall Presenter



Karl Grueneis
AECOM
Environmental Assessment
Planning Lead



Paul Adams
AECOM
Environmental Assessment
Planner



Bander Abou Taka
AECOM
Project Engineer



Jake Helm
City of London
Water Engineering Technologist

City of London Introduction



- Importance of this Project;
- Consultation during COVID-19;
- Being proactive in maintaining and continuously monitoring the transmission main condition and performance ; and
- This presentation builds on the previous Town Hall (June 25th 2020) presented to directly affected property owners.

Public Information Centre (PIC) Purpose



1. Introduce the Project;
2. Provide an overview of the Municipal Class Environmental Assessment (MCEA) process;
3. Highlight the importance of the Arva Pumping Station to Huron Street Transmission Main;
4. Describe the Problem and Opportunity Statement;
5. Describe the existing transmission main easement including:
 - a) The City's ability to access the easement for maintenance and repairs;
 - b) The property owners' easement responsibilities and expectations;
6. Present the alternative short and long term solutions, evaluation and preliminary recommendations; and
7. Meet the project team and get your feedback.



Municipal Class Environmental Assessment (MCEA) Process



- All municipalities in Ontario are required by the provisions of the *Environmental Assessment Act* (EAA) to follow the MCEA process.
- This project is following the MCEA Master Plan Schedule B MCEA process.
- Schedule B projects must follow Phases 1 and 2 of the MCEA process.
- At the end of the EA process, a Master Plan Project File will be prepared for public review and comment.

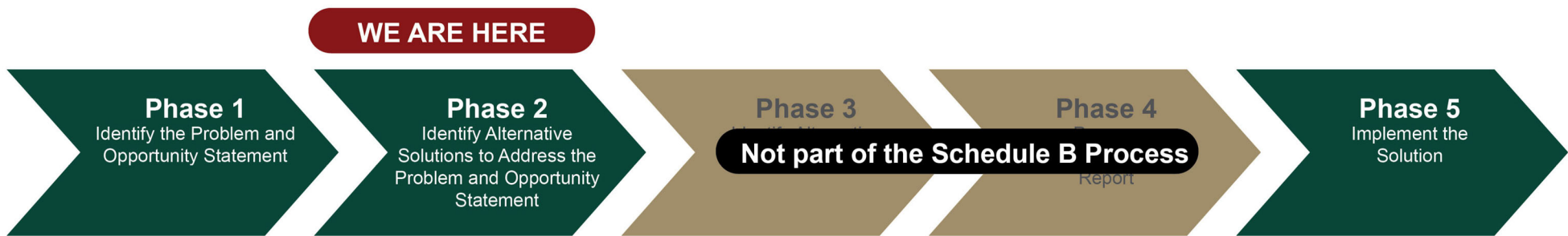

Project Background

The City is supplied with water from two lake-based sources:

80% from Lake Huron - Lake Huron Water Supply System (LHWSS)

20% from Lake Erie - Elgin Area Water Supply System (EAWSS)



Project Background

- The existing transmission main runs from the Arva PS and reservoir to Huron Street.
- This transmission main is the main 'artery' for water supply from the LHWSS.

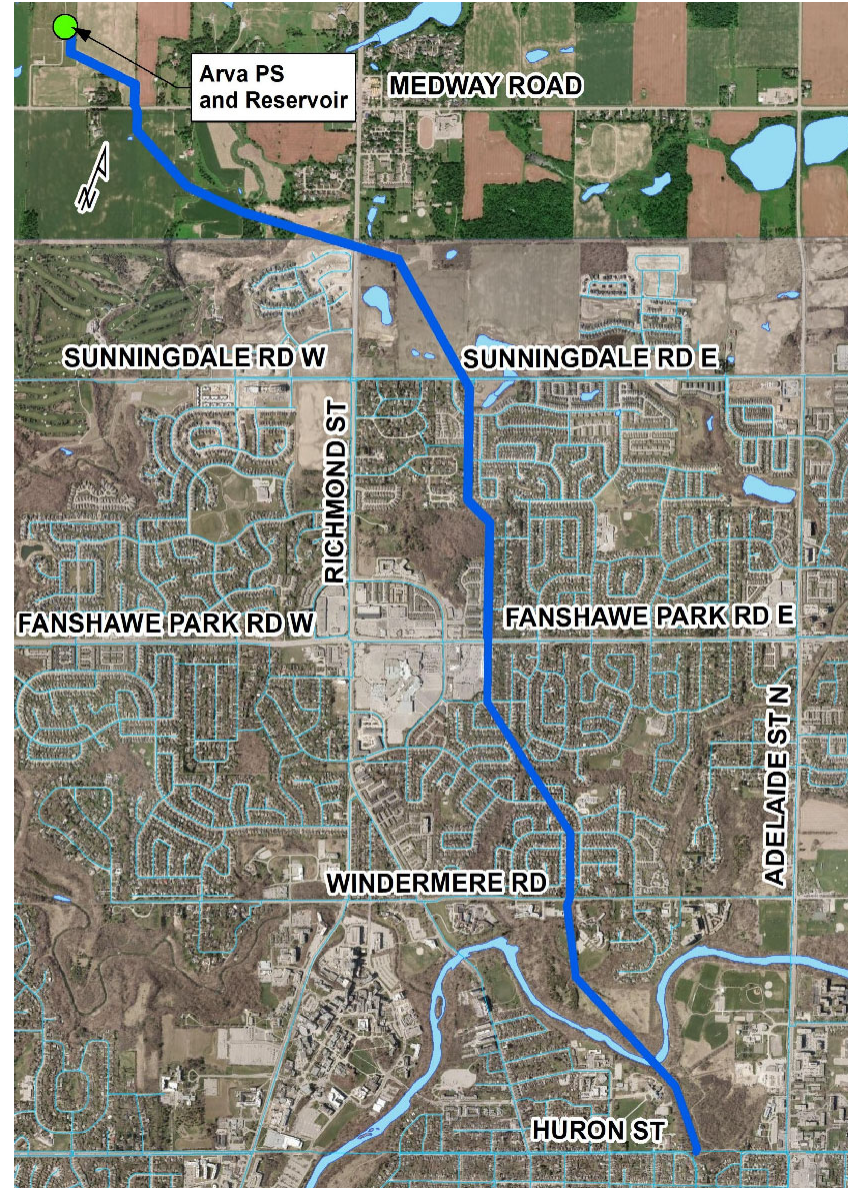

Project Background

- The LHWSS Transmission Main has been partially twinned from the South Huron Water Treatment Plant (WTP), located north of Grand Bend to the City Arva PS.
- The City twinned its transmission main southerly from the Arva PS to Fanshawe Park Road in 1984.
- The transmission main twinning (side by side pipe or new pipe on alternate routes) allows the LHWSS and the City to provide redundancy and capacity in addition to improved maintenance and operations.



Project Background

- The section of transmission main between Fanshawe Park Road East and Windermere Road was originally built in green field areas in 1966.
- Over time land development occurred with agreements and legal easements put in place for access and maintenance to the transmission main which is now surrounded on both sides by residential development (parts of the transmission main are in rear and/or side yards).

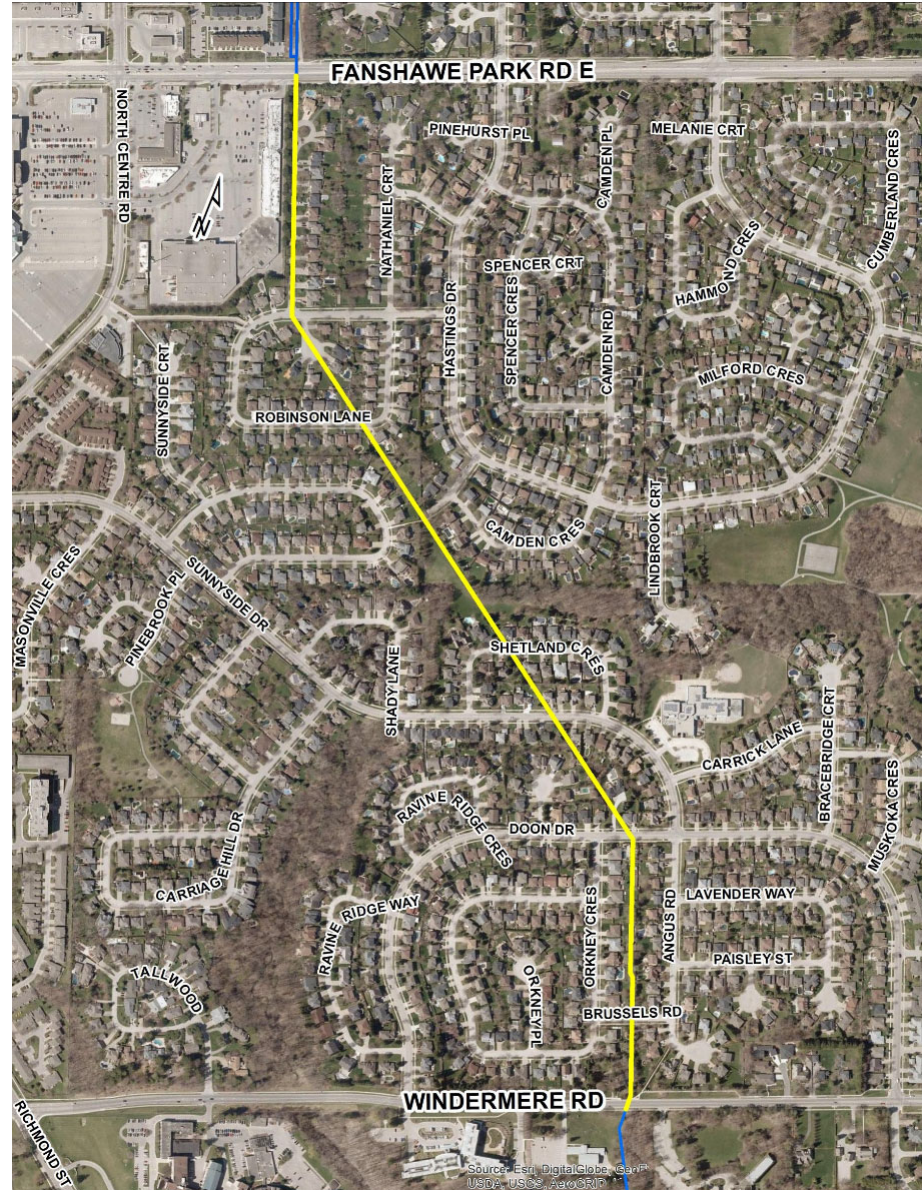

Project Background

- The transmission main between Windermere Road and Huron Street had some pipe sections proactively repaired and replaced recently. It was difficult to access the pipe for the replaced pipe sections because of the narrow easement.
- This led to a review of the entire transmission main easement which found several areas difficult to access along the easement. This means it will be difficult to repair or replace pipe sections in the future if needed.
- Some pipe sections were proactively replaced based on the results of active and continuous pipe monitoring implemented by the City along the entire transmission main.



What is a Transmission Main Pipe and How is it Monitored?

- Concrete pipe with a steel cylinder inside surrounded by more concrete
- Steel wires are inside the concrete providing greater strength
- It is approximately 4' deep (to the top of the pipe)
- 3 types of monitoring technologies from Pure Technologies being used:
 1. Smart Ball
 2. Fiber Optic Acoustic Monitoring
 3. Pipe Diver

Smart Ball

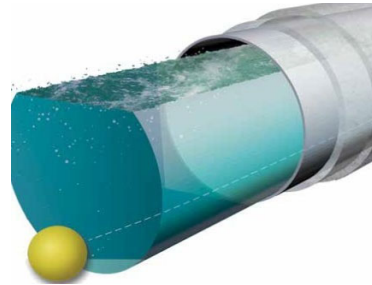

Fiber Optic Acoustic Monitoring

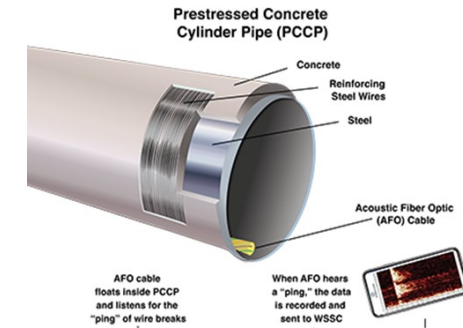

Cross section of a Typical Concrete Transmission Main.

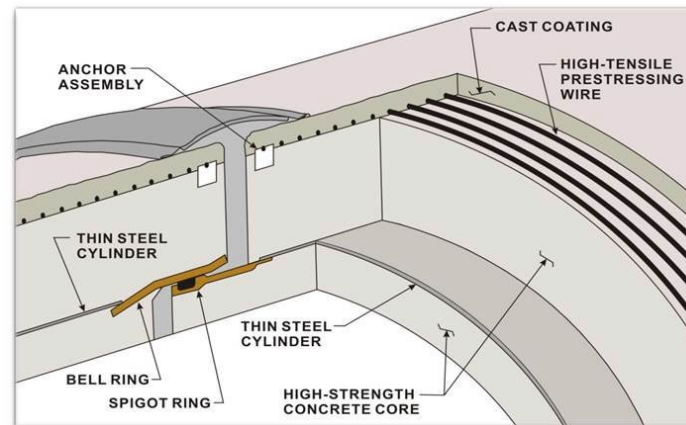

Pipe Diver

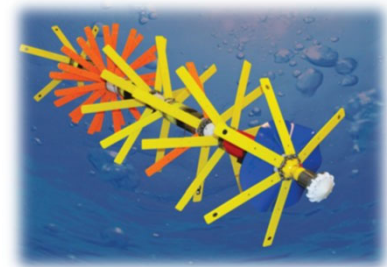

Problem and Opportunity Statement



The Problem and Opportunity Statement is the principal starting point of a MCEA and becomes the central theme and integrating element of the project. It also assists in setting the scope of the project.

Problem:

- The City receives approximately 80% of its water supply from the LHWSS, making the transmission mains that transport this water critical and important assets.
- The transmission main from the Arva PS and Reservoir to Huron Street was constructed in 1966 and ranges in condition, having fair and good sections.
- Several portions of pipe south of Windemere Road and north of the Thames River were proactively replaced in 2017. The existing easement (50' wide) was not adequate to allow for replacement by traditional means.
- Portions of the transmission main run through the backyards of residences where easements are in place (mostly 50' wide).
- **Access to repair the watermain via these easements could be difficult, especially if there are obstacles such as decks, sheds, trees, etc. on top of the easement.**

Problem and Opportunity Statement



Opportunity – The MCEA process provides the City the opportunity to:

- Develop a **short-term strategy and solution** that assesses the existing easements in place to ensure maintenance and repairs can be undertaken as needed;
- Consider the possibility of increasing the easement width to allow for easier access or maintaining them at the current width and enforcing the City's rights to access if maintenance and/or repairs are required;
- Look at twinning the watermain (**long-term strategy and solution**) in other locations (mainly Richmond Street or Adelaide Street) to provide a redundancy of supply (when growth is triggered) and easier maintenance access; and
- Explore the possibility of decommissioning and abandoning the existing transmission main once it has reached its service life.

Why this MCEA and Why Now?



- The City is taking a proactive approach to ensure it can efficiently maintain and repair its infrastructure.
- The study will identify a full range of alternatives and design options and look at easement access in the short-term for repairs and twinning and/or replacement in existing and/or new locations in the long-term.
- The study will ensure that there are short and long-term plans to manage the City's transmission main assets to continue to deliver water supply to its current and future customers.
- The study focus will also look at the best way to meet maintenance and operations objectives, and pipe repair or replacement from a long-term cost impact and operations perspective.
- The MCEA process allows for engagement of the public in the planning and decision making process of the aforementioned items.

Overview of Existing Conditions / Background Studies



Asset Management

The Short-term asset management strategy recommendations include:

- Annual inspection and maintenance of the transmission main valves and chambers
- Soil sampling and testing every 15 years
- Test pits every 15 years
- Free-swimming Electromagnetic Pipe Monitoring every 15 years
- Repair of joints

Natural Heritage

- Natural Heritage features include Thames River North Branch, Arva Moraine Wetland Complex Provincially Significant Wetland (PSW), Gibbons Wetland PSW and Environmentally Significant Area (ESA), North Branch Park and Huron Street Woods and Medway Creek.
- Candidate Significant Wildlife Habitats are present in the Study Area
- Potentially Suitable habitat for Species at Risk (SAR) were identified in the Study Area
- SAR are present in the Study Area

Archaeology / Cultural Heritage

- Stage 1 Archaeological Assessment shows portions of the Study Area have a high potential for the recovery of archaeological resources and a Stage 2 Archaeological Assessment must be conducted before any construction activities commence.
- There are 14 Cultural Heritage Resources identified within the Study including Farmscapes, Places of Worship, and Residences.

Short Term Strategy and Solution (Easement)

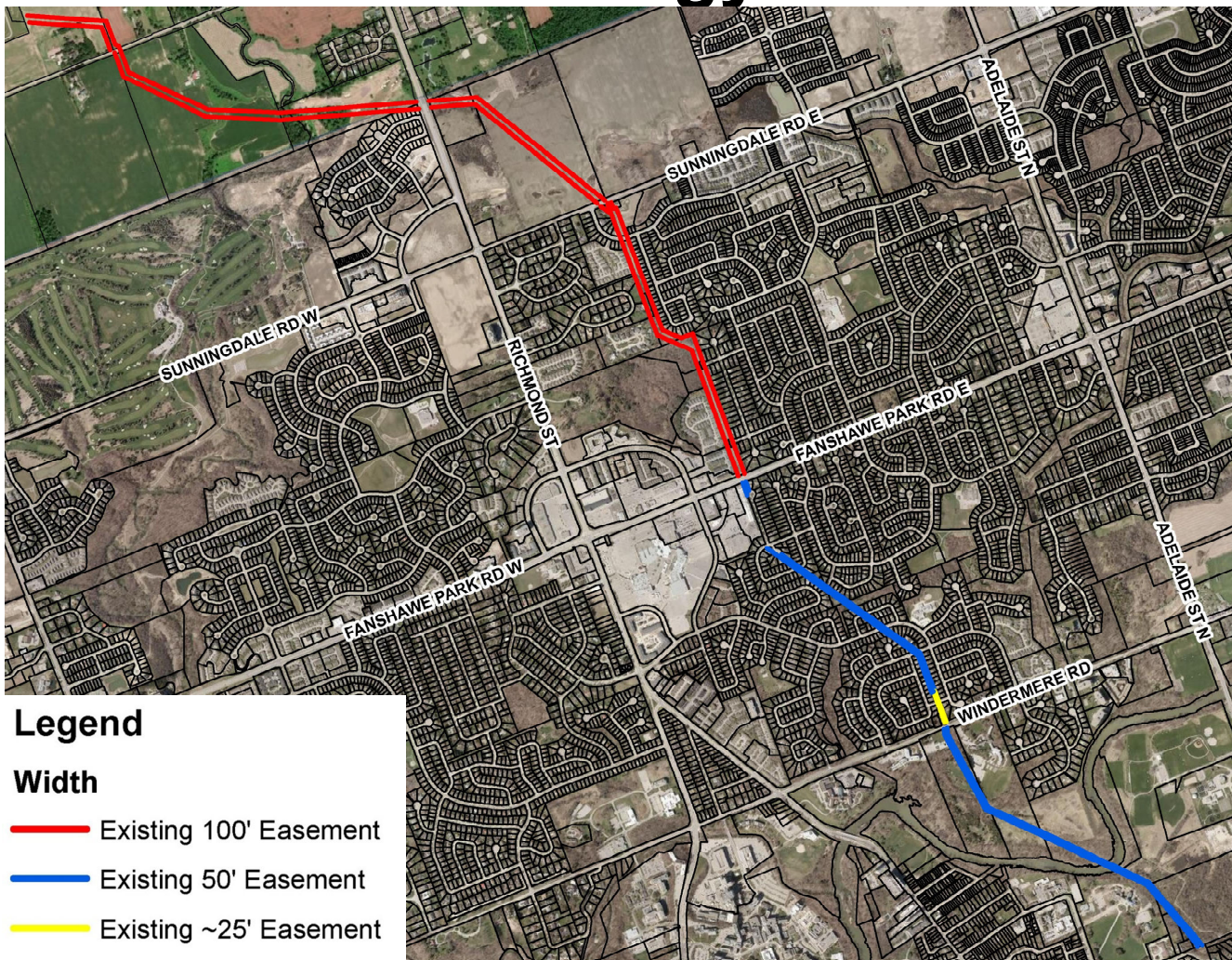

- Assessing the existing easements in place to ensure maintenance and repairs can be undertaken as needed
- Existing easement is 100' (**Red Line**) wide from the Arva PS to Fanshawe Park Road, 50' (**Blue Line**) wide from Fanshawe Park Road to approximately 150m North of Windemere Road and then is reduced to 25' (**Yellow Line**) wide to Windemere Rd.
- Easements shown are based on older drawings and are accurate to about +/-2m

Short Term Easement Alternatives



1

Alternative 1: Do Nothing*

- Maintain the status quo. No improvements are planned or made.
- Continue proactive monitoring, maintenance/repair of the entire Transmission Main.

*A Note About the Do Nothing Alternative

- Consideration of Do Nothing is required as part of the MCEA process.
- Do Nothing means no improvements or changes would be undertaken to address current and future requirements.
- Do Nothing represents what would likely occur if none of the alternative solutions were implemented.
- Does not address the Problem and Opportunity Statement.

Short Term Easement Alternatives



2

Alternative 2: Maintain Easements as is – 50' Wide

- Ensure access is maintained for maintenance and repairs (no structures or obstructions are on the easement).
- No widening of the easement.

Short Term Easement Alternatives







3

Alternative 3: Potentially Widen the Existing Easement to Greater than 50' (if possible)

- Widen the easement to allow for easier maintenance and repair access using conventional construction methods.
- The width of the widening is subject to proximity of existing structures and clear space availability.

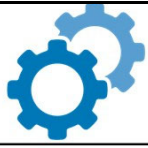
Short Term Easement Alternatives Evaluation Criteria

FACTOR		CRITERIA	DESCRIPTION
SOCIO-ECONOMIC		<ul style="list-style-type: none"> property requirements 	<ul style="list-style-type: none"> Potential impact to private property Ability for owners to use their land Ability to provide equitable dispersal of easement width to all property owners
CULTURAL ENVIRONMENT		<ul style="list-style-type: none"> archaeological resources cultural & built heritage resources 	<ul style="list-style-type: none"> Disturbance to archaeological sites and cultural heritage resources
NATURAL HERITAGE		<ul style="list-style-type: none"> aquatic environment terrestrial environment Species at Risk Source water protection 	<ul style="list-style-type: none"> Impacts/enhancements to aquatic and terrestrial species and habitat Effects of the project on source water resources (ie. Wetlands)
TECHNICAL		<ul style="list-style-type: none"> Asset management Performance 	<ul style="list-style-type: none"> Ongoing monitoring and maintenance (M&M) Increased soil and visual testing Proactive joint/pipe section repairs
Economic and Financial		<ul style="list-style-type: none"> On going monitoring and maintenance costs Emergency repair costs Property/Easement agreement costs 	<ul style="list-style-type: none"> Cost to access transmission main for repairs Costs to access transmission main during emergency Cost to negotiate a new easement width with property owners

Short Term Easement Alternatives Evaluation Scale



Low Impact is considered preferred compared to moderate or high impact

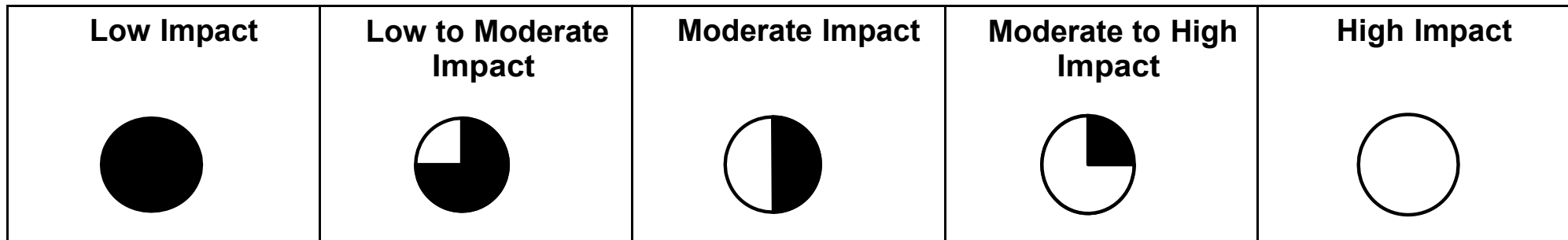

Environmental Impact Increases

Short Term Easement Alternatives Evaluation

Overall Evaluation Summary



Arva Pumping Station to Huron Street Water Transmission Main

Factor / Criteria	Alternative 1: DoNothing	Alternative 2: Maintain Easement as is 15m-30mWide	Alternative 3: Widen the Easement to Greater than 15m up to 30m (if/where possible)	Rationale
Socio Economic Summary				<ul style="list-style-type: none"> Alternative 3 requires significant property/easement agreements Alternative 1 restricts quick access to the transmission main in an emergency
Cultural Environment Summary				<ul style="list-style-type: none"> Alternative 1 and 2 have minimal impact due to less chance of encroachment into areas of significance Alternative 3 would have more impact due to clearing obstructions <u>and</u> adding easement width.
Natural Heritage Summary				<ul style="list-style-type: none"> Alternative 1 would have lowest impact. Greater impact if emergency works are required Alternatives 2 and 3 would have greater impact due to removal of obstructions and/or for the increased easement width
Technical Summary				<ul style="list-style-type: none"> Alternative 1 does not facilitate easy access for repairs Alternative 3 provides easier access allowing for lower Monitoring and Maintenance costs.
Economic and Financial Summary				<ul style="list-style-type: none"> Alternative 1 has high costs associated with access in an emergency due to obstacles Alternative 3 has very high costs associated with significant property and easement agreements

Short Term Easement Alternatives Evaluation

Overall Evaluation



- Alternative 2 does not require additional easements or property
- Alternative 2 has lowest costs associated with easement agreements and emergency repairs

Recommended Short Term Easement Design Concept



In order to conduct inspections and maintenance activities, access to the transmission main and valve chambers is required, as per the rights and privileges granted to the City in the existing Easement Agreements.

To ensure easy and safe access the City will notify property owners of the requirements based on three levels of risk:

- **Level 1 - Areas of Low Risk**, properties with no valve chambers, non-fenced areas with little to no obstacles within the easement or properties that City Staff can access immediately with minimal obstacle* removal to maintain, monitor and/or repair any damage to the transmission main – **Green areas on the following map**
 - **For properties within this area it will be recommended to remove or relocate easement obstacles* on their properties (within reason) in order to facilitate access to City owned infrastructure.**
- **Level 2 – Areas of Medium Risk**, properties with a valve chamber on it that requires access to inspect or repair, or has multiple obstacles* preventing access for maintenance or repair – **Orange areas on the following map**
 - **For properties within this area obstacles* will need to be removed or relocated to facilitate access to City owned infrastructure.**
- **Level 3 – Areas of High Risk**, properties with critical valve chambers that require regular maintenance and inspections to ensure the valves are operating adequately- **Red Areas on the following Map**
 - **For properties within this area, home owners will be required to remove or relocate easement obstacles* to facilitate access to City owned infrastructure.**

***The City is not obligated to repair or compensate owners for any damages caused by removing any obstacles like trees within 3m of the transmission main, sheds, decks, concrete pad, fixed playground sets, etc. within the City's easement. The City Will reinstate areas to previous conditions or better, minus any obstacles within the easement.**





Short Term Easement Alternative Risk Levels

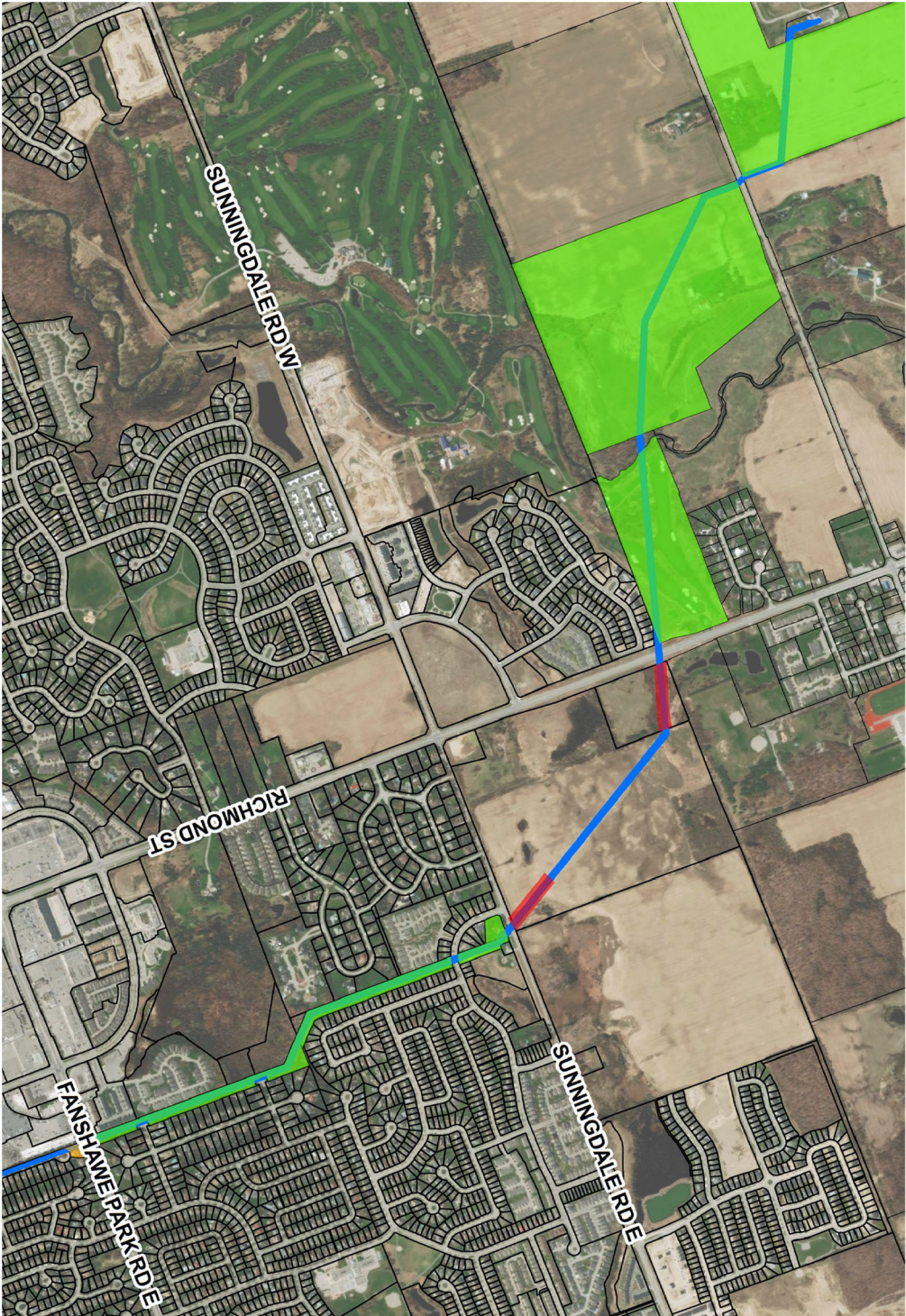

London
CANADA



Legend

-  Existing Transmission Main
-  Existing Lot Lines
-  High Risk Area
-  Medium Risk Area
-  Low Risk Area

Short Term Easement Alternative Risk Levels

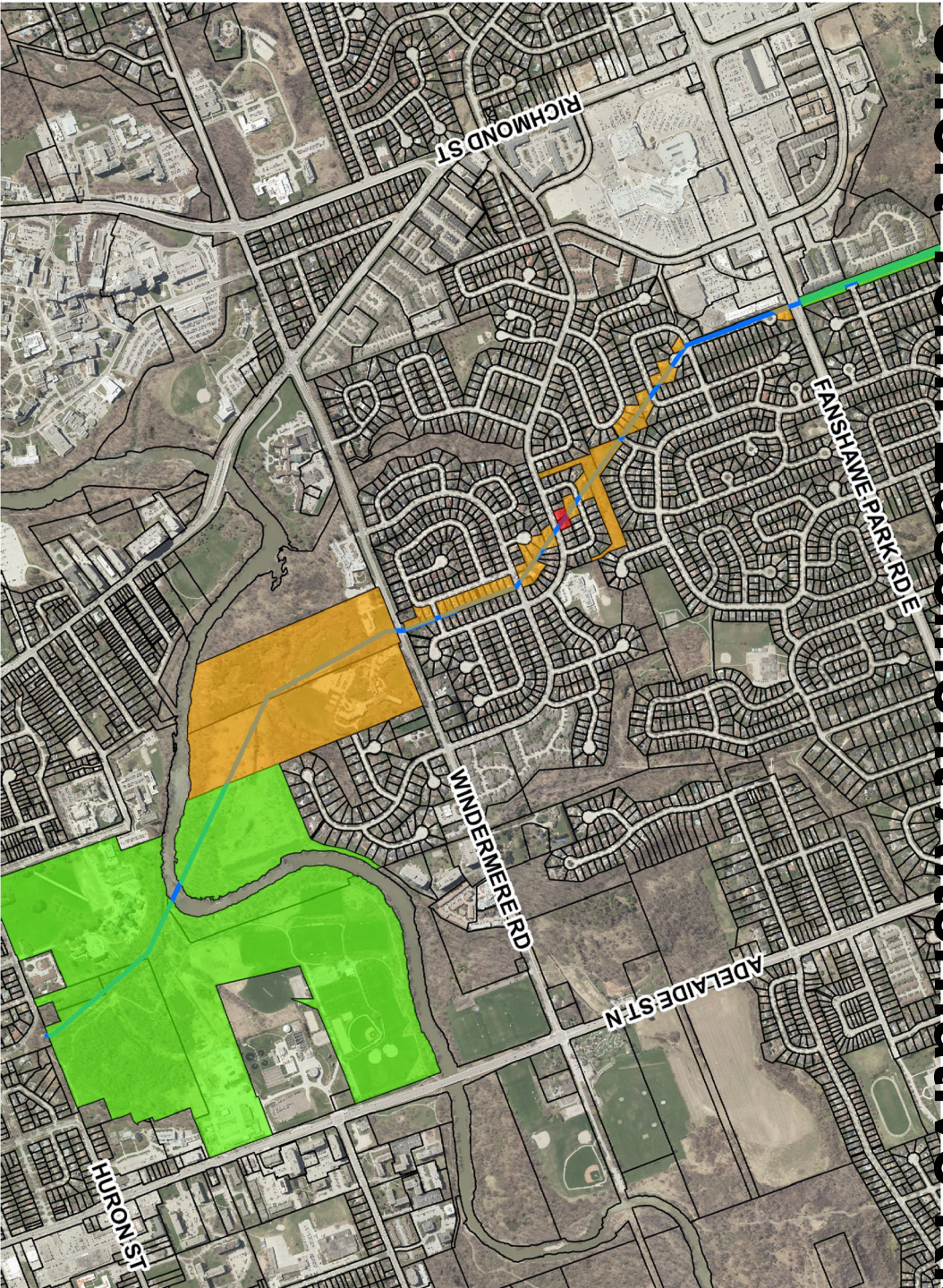

Legend

- Existing Transmission Main
- Existing Lot Lines
- High Risk Area
- Medium Risk Area
- Low Risk Area

Long Term Transmission Main Twinning Alternatives

- Once the transmission main has been twinned and the end of service life for the existing transmission main has been reached it may be possible to decommission the existing main in place.

Legend

- Existing Transmission Main
- Alternative 2: Adelaide Street Twinning Routes
- Alternative 3A: Richmond Street North Twinning Routes
- Alternative 3B: Richmond Street South Twinning Routes

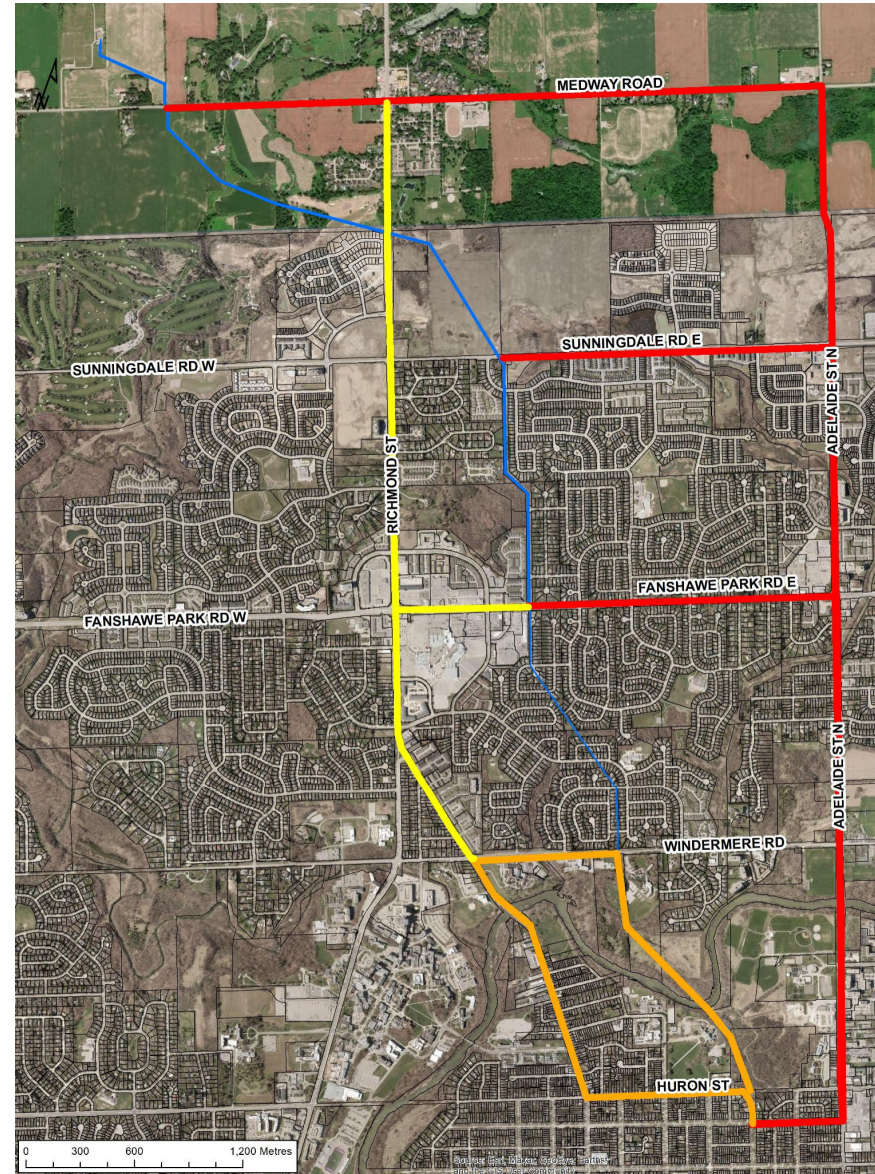

Long Term Transmission Main Twinning Alternatives



1

Alternative 1: Do Nothing

- Maintain the status quo.
- No improvements are planned or made.

Long Term Transmission Main Twinning Alternatives

2

Alternative 2: Twin the Transmission Main Along Adelaide Street with a connection to the existing main at either:

- Medway Road; or
- Sunningdale Road; or
- Fanshawe Park Road; and on
- Regent Street

Legend

- Existing Transmission Main
- Alternative 2: Adelaide Street Twinning Routes
- Alternative 3A: Richmond Street North Twinning Routes
- Alternative 3B: Richmond Street South Twinning Routes

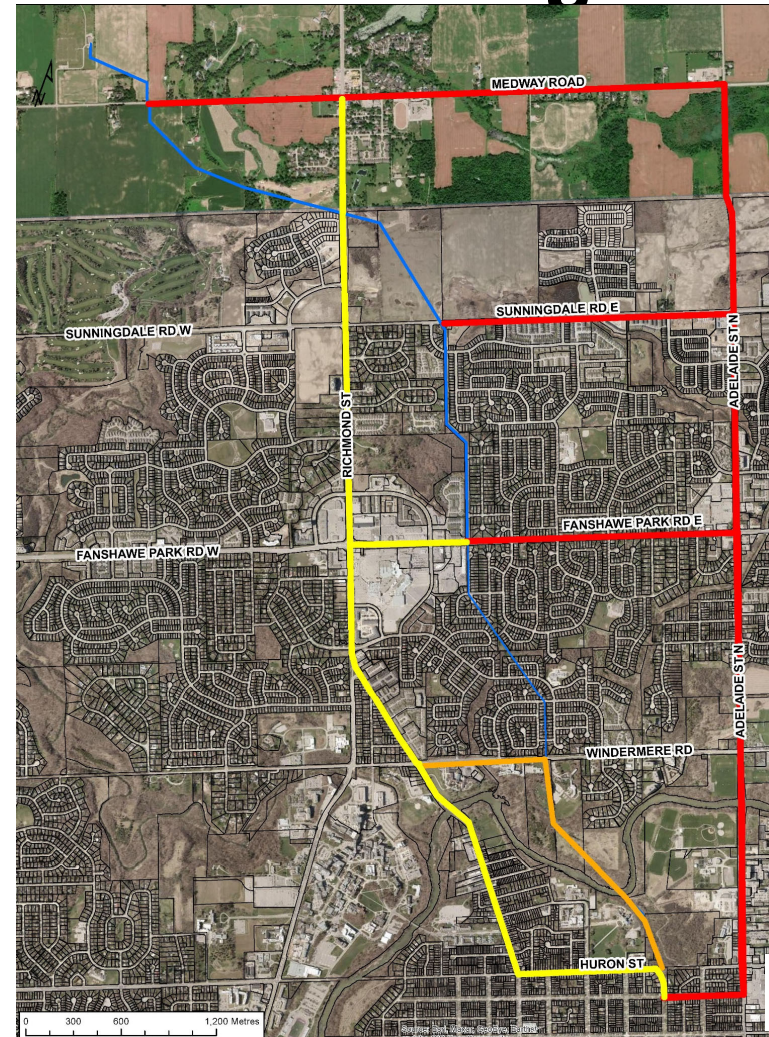

Long Term Transmission Main Twinning Alternatives

3A

Alternative 3A: Twin the Transmission Main Along Richmond Street North, with a connection to the existing main at either:

- Medway Road and on Richmond Street (North of Sunningdale); or
- Fanshawe Park Road

Legend

- Existing Transmission Main
- Alternative 2: Adelaide Street Twinning Routes
- Alternative 3A: Richmond Street North Twinning Routes
- Alternative 3B: Richmond Street South Twinning Routes

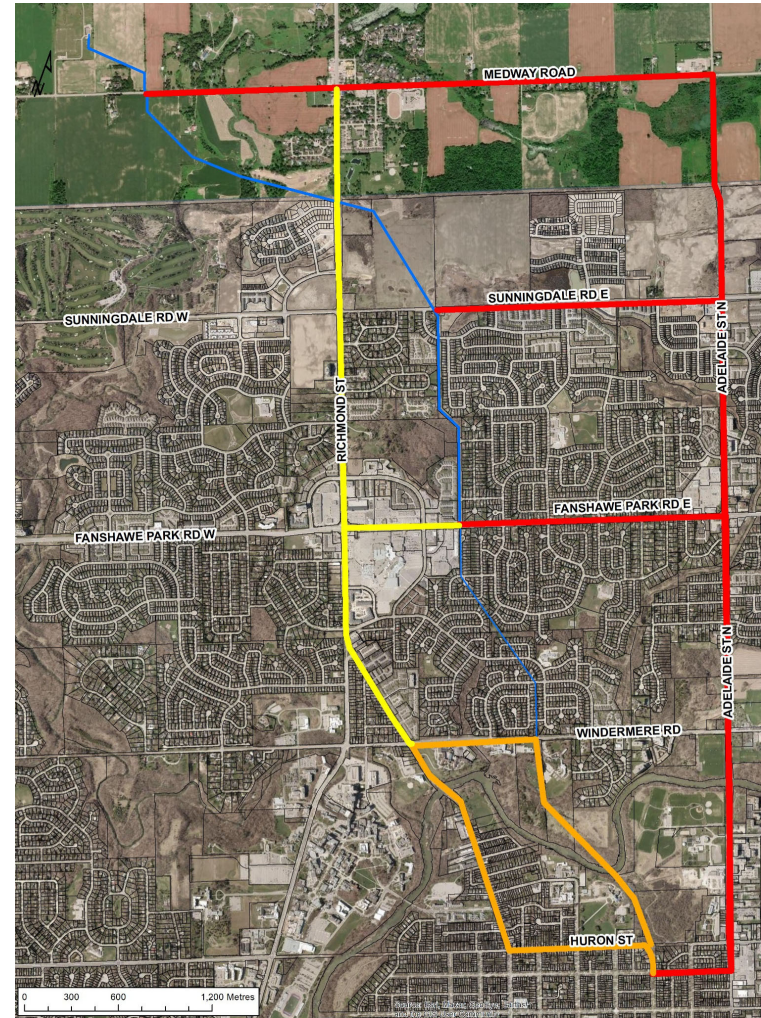

London
CANADA

AECOM

Long Term Transmission Main Twinning Alternatives

3B

Alternative 3B: Twin the Transmission Main Along Richmond Street South with a connection at:

- Windemere Road and via the existing easement; or
- Huron Street

Legend



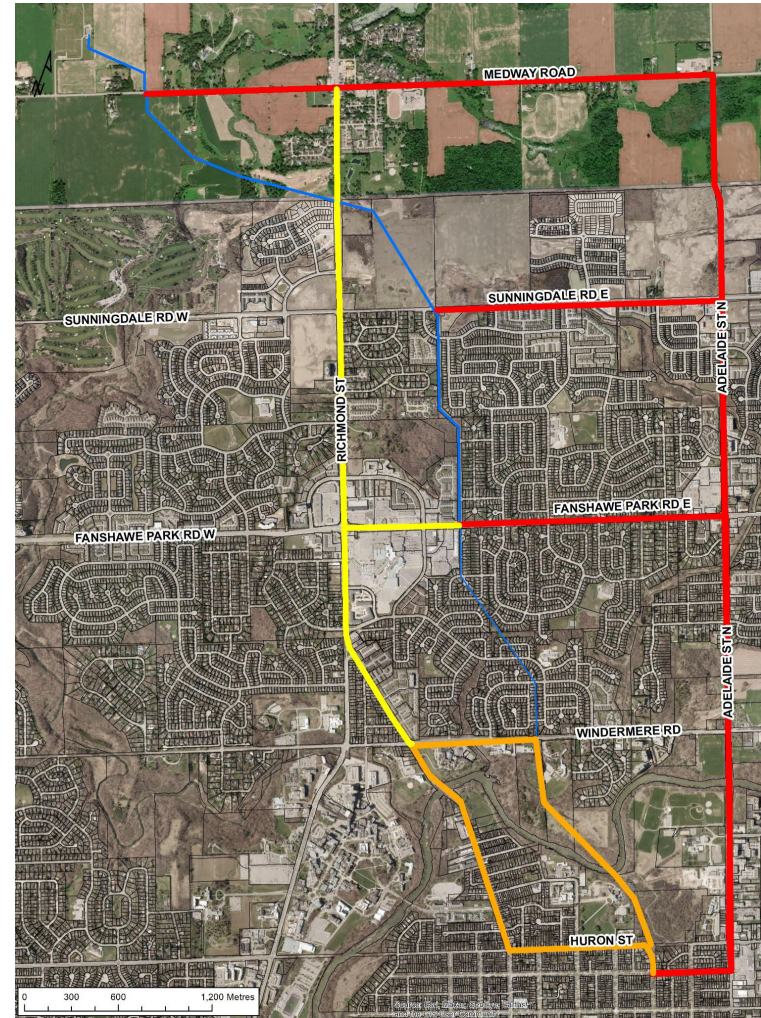

- Existing Transmission Main
- Alternative 2: Adelaide Street Twinning Routes
- Alternative 3A: Richmond Street North Twinning Routes
- Alternative 3B: Richmond Street South Twinning Routes



London
CANADA

AECOM

Long Term Twinning Route Alternatives Evaluation Criteria

SOCIO-ECONOMIC		<ul style="list-style-type: none"> • property requirements • Construction Impacts • Disruption of service 	<ul style="list-style-type: none"> • Permanent/Temporary Impact to private/public lands • Potential impacts to existing/future land use • Potential property requirements • Potential nuisance impacts • Travel delays due to construction • Disruption to businesses • Potential to affect the reliability of service during construction
CULTURAL		<ul style="list-style-type: none"> • archaeological resources • cultural & built heritage resources 	<ul style="list-style-type: none"> • Disturbance to archaeological sites and cultural heritage resources
NATURAL HERITAGE		<ul style="list-style-type: none"> • aquatic environment • terrestrial environment • Species at Risk • Source water protection and Climate change 	<ul style="list-style-type: none"> • Impacts/enhancements to aquatic and terrestrial species and habitat • Effects of the project on source water resources (i.e. Wetlands) • Resilience to extreme weather events • Reducing the effect on climate change
TECHNICAL		<ul style="list-style-type: none"> • Water Quality • Hydraulics • Transient Protection • Design and Constructability • Operations and Maintenance 	<ul style="list-style-type: none"> • Ability to maintain/reduce potable water turnover • Storage Balancing • Ability to mitigate high/low pressures • Ability to mitigate high/low velocity and head loss • Transient protection • Air valve needs • Construction complexity • Energy consumption
Economic and Financial		<ul style="list-style-type: none"> • Capital Costs • Operation and Maintenance Costs • Property Costs 	<ul style="list-style-type: none"> • Cost to construct • Costs to operate and maintain the system • Cost to purchase required property

Long Term Twinning Route Alternatives



London
CANADA

Overall Evaluation Summary

Factor / Criteria	Alternative 1: Do Nothing	Alternative 2: Twin the Transmission Main Along Adelaide Street with a connection to the existing main at either: Medway Rd, Sunningdale Rd, Fanshawe Park Rd and at Regent Street	Alternative 3A: Twin the Transmission Main Along Richmond St North from Windermere Rd with connections at Medway Rd or Fanshawe Park Rd	Alternative 3B: Twin the Transmission Main Along Richmond St South via Windermere Rd/Easement or Huron Street	Rationale
Socio Economic Summary					<ul style="list-style-type: none"> Alternative 1 high impacts in an emergency due to 15m or less easement widths Alternative 3A and 3B may require easements or property acquisition. Alternative 2 no apparent property easements or acquisitions required. Alternatives 2 and 3 have similar construction impacts.
Cultural Environment Summary					<ul style="list-style-type: none"> Alternative 2 and 3B have higher potential for Archaeological impacts. Alternative 3B has the highest potential for cultural heritage impacts.
Natural Heritage Summary					<ul style="list-style-type: none"> Alternative 1 has high impacts for repairs in significant terrestrial areas. Alternative 2 has the most water crossings, and a greater potential to impact SAR Alternative 3A has less water crossings and a lower potential to impact SAR Alternative 3B has fewer but more significant water crossings than 3A, a higher potential to impact SAR and a greater impact to climate change due to reduced carbon sequestration capacity resulting from vegetation removal
Technical Summary					<ul style="list-style-type: none"> Alternatives are technically (hydraulics/water quality) equal except Alternative 1 which would require increased monitoring and maintenance. Alternative 3A and 3B have a greater design complexity
Economic and Financial Summary					<ul style="list-style-type: none"> All Alternatives have similar costs associated with them. Alternative 1 has high emergency repair costs.
Overall Evaluation					<ul style="list-style-type: none"> Alternative 1 has significant emergency repair impacts Alternative 2 the least impacts and the clearest route for twinning

Arva Pumping Station to Huron Street Water Transmission Main

Recommended Long Term Design Concept



London
CANADA

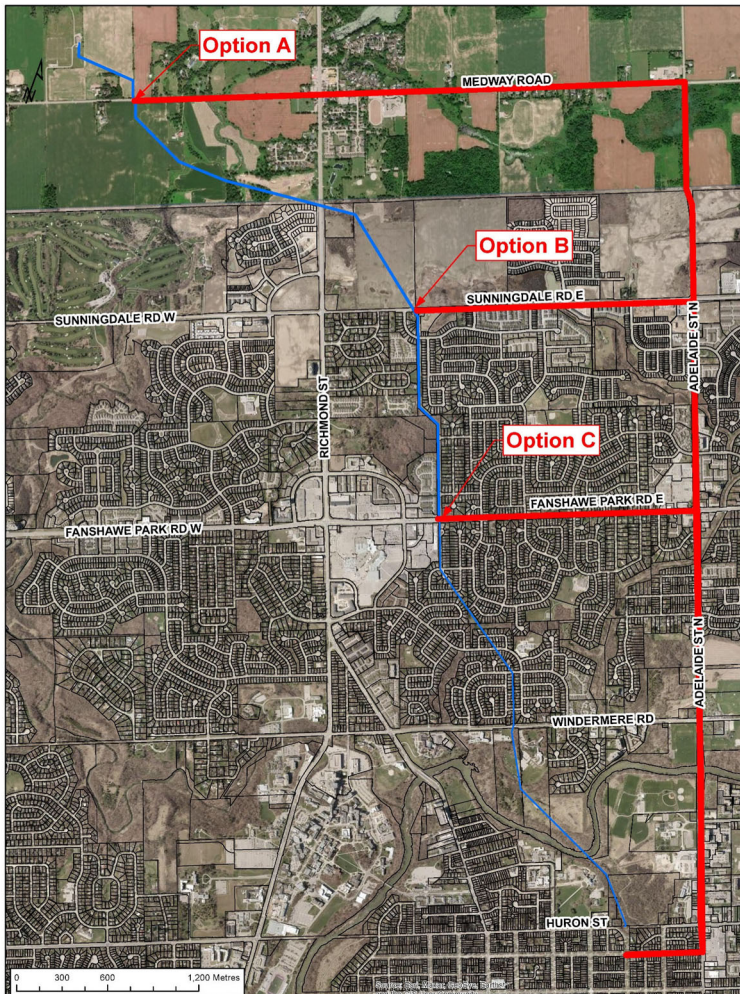

- The new transmission main will be within an existing Right of Way (ROW) along Adelaide Street North with three options to connect to the existing transmission main.
- Connecting at Fanshawe Park Road (Option C) is the preferred connection point. Option A and B may be looked at as part of modeling and master planning to service Northeast London in the future
- The existing utilities in the roadway, including water, sanitary and storm were evaluated to confirm a transmission main route that limits disruption to existing utilities, reduces bends and abrupt change in direction, and limits the need to purchase or obtain additional land or easements outside City owned properties.

Typical Cross Section of a Twinned Watermain in a Right of Way

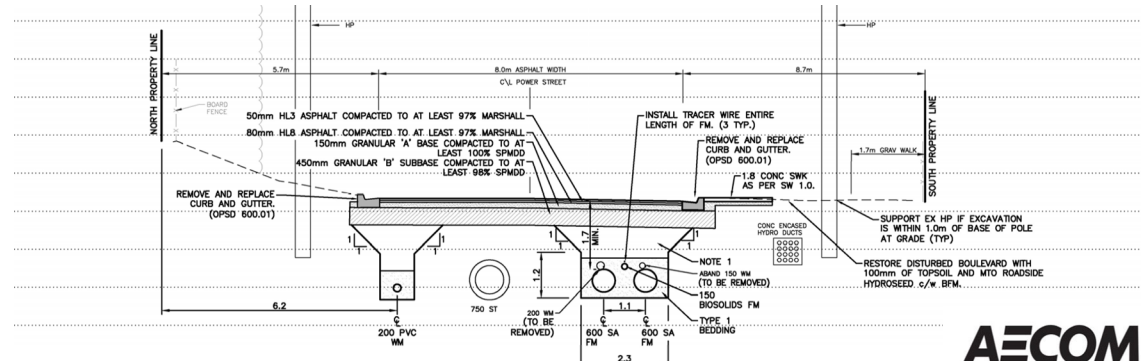

AECOM

Next Steps



- Comments received from this PIC will be collected until December 11 2020, reviewed and considered by the project team and become part of the public record.
- Public input from this meeting will be considered when finalizing the evaluation.
- An EA Master Plan Project File will be prepared and made available for public review online for 30 days.
- If no issues are raised within the 30-day review period, the City can proceed to detailed design, approvals and construction.
- Detailed design would be completed, and construction can begin for any short-term measures.

For More Information

Ask a Question Today

- Use the **Q&A window** - type in your question and hit send. Our speakers will be answering questions in a few minutes.

Visit the Project Website

- <https://london.ca/projects/arva-pumping-station-huron-street-water-transmission-main-master-plan>
- A link to a Virtual Room, where an overview of the presentation materials and additional comment forms can be found will be located on the project web page, or by going to: www.LondonWatermain.ca (for best results view using **Google Chrome**)



Contact the Project Team

- Contact us with additional comments or questions at any time.

We appreciate the time you have taken to learn more about the project and value your input to this study and encourage you to stay connected.



Stephen Romano, P.Eng

Project Manager
 Corporation of the City of London
 300 Dufferin Avenue
 London ON, N6A 4L9
 Tel: 519-661-2489 x5537
 Email: sromano@london.ca

John Haasen, PMP, CET

Project Director,
 AECOM Canada Ltd.
 250 York Street, Suite 410
 London ON, N6A 6K2
 Tel: 519-963-5889
 Email: john.haasen@aecom.com

Adams, Paul (London ON)

From:

Is this the property with the chamber on it? If so I just offered to meet with the owner on Sunnyside so we can tee both up to look at. John

John Haasen, PMP, CET
Senior Vice President,
Project Delivery Excellence,
Canada D +519-963-5889
M +519-871-0210
john.haasen@aecom.com

AECOM Canada Ltd
250 York Street, Citi Plaza
Suite 410
London, Ontario N6A 6K2, Canada
T +519-673-0510
aecom.com

Built to deliver a better world

[LinkedIn](#) [Twitter](#) [Facebook](#) [Instagram](#)

Transmission Main Good Morning Stephen,

The home owner at 139 Orkney Cres is requesting an in person meeting to discuss the easement on their property. See email below.

Paul

Paul Adams CPT
Environmental Planner / GIS Specialist, Environment
D +1-519-963-5873
C +1-519-636-6448
Paul.Adams2@aecom.com

AECOM Canada Ltd.
250 York Street
Suite 410
London, Ontario N6A 6K2, Canada
T +1-519-673-0510
aecom.com

Imagine it. Delivered.

[LinkedIn](#) [Twitter](#) [Facebook](#) [Instagram](#)

From:

To: Adams, Paul (London ON) <Paul.Adams2@aecom.com>

Subject: [EXTERNAL] Re: Arva Pump Station to Huron Street Water Transmission Main

Thank you for the information provided.

As mentioned in the meeting that city can visit, can I have someone come to have a look at easement at 139 OrkneyCres please. I can be available at anytime. Thanks.

On Wed, Nov 25, 2020 at 7:28 PM Adams, Paul (London ON) <Paul.Adams2@aecom.com> wrote:

Thank you for registering for and/or attending the Virtual Public Information Centre this evening. Information regarding this project can be found on the City of London Project website:

<https://london.ca/projects/arva-pumping-station-huron-street-water-transmission-main-master-plan>

The Virtual Open House is live now and can be accessed by following the link below (copy and paste the link into Google Chrome for the best viewing/access). A recording of this presentation (once uploaded), key slides and contact information can be found here:

<https://www.londonwatermain.ca/>

Regards,

Paul.

Paul Adams CPT
Environmental Planner / GIS Specialist, Environment
D +1-519-963-5873

C +1-519-636-6448
Paul.Adams2@aecom.com

AECOM Canada Ltd.
[250 York Street](#)

[Suite 410](#)
[London, Ontario N6A 6K2, Canada](#)
T +1-519-673-0510
aecom.com

Imagine it. Delivered.

[LinkedIn](#) [Twitter](#) [Facebook](#) [Instagram](#)

Adams, Paul (London ON)

From: Haasen, John
Sent:

Jim, see my comments below in red. Stephan will call you to go over in more detail. John

John Haasen, PMP, CET
Senior Vice President,
Project Delivery Excellence,
CanadaD +519-963-5889
M +519-871-0210
john.haasen@aecom.com

AECOM Canada Ltd
250 York Street, Citi Plaza
Suite 410
London, Ontario N6A 6K2, Canada
T +519-673-0510
aecom.com

Built to deliver a better world

[LinkedIn](#) [Twitter](#) [Facebook](#) [Instagram](#)

From:

Cc: sromano@london.ca; Adams, Paul (London ON) <Paul.Adams2@aecom.com>; Abou Taka, Bander <Bander.AbouTaka@aecom.com>

Subject: [EXTERNAL] Re: Regarding Arva Pumping water main project | High risk

area. Good afternoon John,

Thank you so much for taking time to write in detail ; you have no idea how much it means to us – so a big thank you and glad to know that we are kind of safe. I tried to Google what exactly a drain value does but not much information I could find. Does it mean the water will gush out of that opening and flood the area if there are any issues? **No, it will have to be opened manually and a plan will be in place to direct water to the nearest roadway** Do I need to take any precaution as my basement is finished to avoid flooding? **No**

I talked to neighbors regarding on Saturday ; they are equally worried and almost all of my neighbors are closer to retirement age and I cannot imagine the impact if city decides to keep this line for long. I will talk to my neighbors if they are willing to meet up, but as I mentioned earlier 90% of neighbors are above 60 plus, so due to COVID I doubt they will come. **A site mtg would be socially distanced to accommodate**

Jon, I can see your care for us from your email and we truly appreciate that. I am all for our London's development ; We also believe city will take right decision to cater Londoners water need without ripping our neighborhood and families apart.

Thanks again Jon. Have a great afternoon.

Regards,
Jim
Jacob.
226 700 7030.

From:

Subject: RE: Regarding Arva Pumping water main project | High risk area.

Hi Jim. Thank you for your email expressing your concerns. We have tried to alleviate as many as we can for now as per the comments I provided below in red. We are open to meeting with you and your neighbors on your property this week if we can find a time that works for all around the weather to go over with you. Please provide some dates and times that work for you. We look forward to meeting you. John

John Haasen, PMP, CET
Senior Vice President,

Project Delivery Excellence,
CanadaD +519-963-5889
M +519-871-0210
john.haasen@aecom.com

AECOM Canada Ltd
250 York Street, Citi Plaza
Suite 410
London, Ontario N6A 6K2, Canada
T +519-673-0510
aecom.com

Built to deliver a better world

[LinkedIn](#) [Twitter](#) [Facebook](#) [Instagram](#)

From: Jim J < Saturday, November 28,
2020 11:14 AM **To:** Haasen, John
<John.Haasen@aecom.com>

Subject: [EXTERNAL] Re: Regarding Arva Pumping water main project | High risk area.

Hi Jon, I got your email wrong ; resending to correct email address.

From:

Sent: November 28, 2020 11:12 AM

To:

NOTE: This email is just for your eyes only and should not make it public , please. Thank you.

Good morning Stephen and John,

Hope you both are doing well and in good health. My family consists of myself, wife and 3 little kids ; so we couldn't attend Arva waterline public meeting because of our job schedule and taking care of little ones **Understood**

However I saw the video presentation on London city website regarding that, thanks for posting it. **Your Welcome**

We purchased our house , 186 Sunnyside with big dreams ; like any other young family just couple months back. Now from the map and from city's communication , I came to know it's one of the main water line in city and as a shock - my house was marked as critical / high risk area. I was told in last 30 years no one bothered with the line (when I asked realtor what exactly that small concrete thing in back of the house) by the realtor. After watching today's video presentation, really troubled in mind that we almost paid closer to a million dollars to purchase this house and OfCourse mortgage. **The Transmission main itself is in good condition for being just over halfway of its anticipated lifespan. It is monitored constantly by the City along with periodic checks and investigations which to date have not required allot of visibility to the public. Because we are entering the later stages of the transmission main's lifespan we have recommended more frequent and additional monitoring that will require more visibility and access in the future. As a result even though the transmission main's failure potential is low, the fact it is in the backyards of residences makes the consequence of any potential failure high. In addition the chamber on your property is the main drain valve for the transmission between Fanshawe Park Road and Windermere Road thereby requiring additional access and attention for maintenance purposes. As a result a Level 3 risk was assigned to it.**

I promptly contacted city and entered into lease with city and lease is now transferred to my name from previous owner. In that lease agreement, it shows it's 25 feet (width) by 120 feet (length) ; so I am not getting what is this 50 feet width which you mentioned in the video. **We will have to look into your specific property details in the future, but because the transmission main is partially on your property and on your neighbors to the east, the existing 50ft easement on either side of the transmission main centerline is likely shown as 25ft along your eastern property line, and 25ft along your neighbor's.**

I understand we all need water to survive and I am open to help and work with city for all reasonable requests. Now I am wondering, is city is planning to do some major work on that chamber as it's marked as critical area. Or no changes ? **Not likely for either, just increased access and maintenance but that will be subject to what they find and if any repairs are needed** Is there anything I should be worried as I happen to buy this house at this high risk area without any previous knowledge. **No not at all** What does that high risk means ? **See above for the explanation provided** Does it do any harm to my little ones or my family like pipe bursting in high pressure or something? **The likely hood of bursting is low given the operating conditions, the lower pressures though this portion of the transmission main and the proactive monitoring and maintenancethe City does.**

I am kind of lost here with the amount of information shared; so kindly share your thoughts on :

1. City lease says 25 feet width , video presentation says 50 feet ; if 50, that's going through the bedroom of the house! **See the explanation above, but the easement is existing and we have recommend against any further widening so nothing should be going through your house**
2. As my house is marked in high risk area : **See the explanation above**
 - a. Is there any harm to me and my family ? **No**
 - b. Should we expect city to come anytime with a bulldozer and rip off the yard? **No**
 - c. Please define high risk - high risk for what? **See the explanation above**

If you have been living in London for last two decades, you know London city's population exponentially grown in last decade, might be high time for city to start working on alternatives and (not wait for another 5 years) and close these high risk small water lines running through our backyards? **This is why we have recommend a new transmission route along Fanshawe Park Road, Adelaide Street and Regent Street be implemented in the next 0 to 20 years with room for 2 transmission mains in the future. The City's intention is to continue to monitor and maintain the transmission main through you property, build the 1 or 2 additional transmission main portions recommended and then decommission the existing transmission main the last 20 to 25 year of its anticipated lifespan.**

Jon and Stephen, I completely understand you both are helping us by trying to give some heads up ; but there are many people who will lose sleep because of this (talked to neighbours and they too share same feeling) . I am all in to serve my nation and my city ; but family is important too as you can imagine. **Understood. We would be more than happy to meet with you and your neighbors at your convenience.**

Kindly reply for my 2 questions at your convenience and please feel free to reach me directly as well at 226 700 7030. **Hopefully we have alleviated your concerns to the extent possible, and we are more than happy to follow up by phone or in person. John**

Regards,
Jim

NOTE: This email is just for your eyes only and should not make it public , please. Thank you.

Adams, Paul (London ON)

From: Romano, Stephen <sromano@london.ca>
Sent:

y,
Thanks for the questions. Please see my responses below in red.
Regards,

Stephen Romano, M.Eng, P.Eng
Environmental Services Engineer
Water Engineering Division
City of London

-----Original Message-----

From: Water Transmission Main <john.holst@aecom.com>
Sent: Friday, December 11, 2020 10:56 AM
To: Romano, Stephen <sromano@london.ca>
Subject: [EXTERNAL] Arva Contact Form Submission

Name

Message:

I have a question and feedback related to the recommended long term solution.

A) Question

What does the use of the term “twinning” mean with regards to the new water main line being recommended? Does it mean one new line “twinned” with the existing line or two new lines to eventually replace the existing line, especially the section through the residential neighbourhoods in north London? During the summer public meeting I recall this was an aspect being considered as part of the long term solution, but I did not see it specified in the documentation available through this open house.

Twinning of the watermain would involve installation of two pipes of the same size beside each other along this same route. This provides the benefit of being able to take one of the sections of pipe out for maintenance and repairs, ensures there is redundancy in the event one of the sections of pipe breaks so that the City still receives clean water through the other section and provides increased capacity if needed. The option of twinning the existing pipe through the residential neighborhoods was eliminated early in the project as it would have required the City attaining more land to excavate which wouldn't be possible with the development around it. Therefore, now that Adelaide St has been chosen as the long-term solution, the plan is to have new twinned lines installed down Adelaide St and the current watermain going through the residential areas would be abandoned or decommissioned.

B) Feedback

I would prefer to see the northerly connection to the existing water main line, as part of the long term solution be by using Sunningdale Rd rather than Fanshawe Rd. Fanshawe is one of the most

heavily trafficked roads in the city and the extended impact on all who use this road, including accessing Masonville mall and the surrounding businesses will be tremendous. The lands around Sunningdale Rd are in the process of being developed and I expect the roads will need to be re-worked and widened within a foreseeable period of time. I believe it makes more sense to extend the new line up Adelaide to Sunningdale Rd and then west along Sunningdale Rd to connect to the transmission main as it enters the city.

Through this project, only the north-south route of using Adelaide has been finalized. We are suggesting using Fanshawe Park Rd as the east-west route right now, but it will be reevaluated with Sunningdale Rd and Medway Rd closer to when the new pipe actually gets installed. Your comment will certainly be included in the project file and taken into consideration. The traffic situation will be taken into consideration along with many other factors including elevation changes, growth in the northeast area of the City and the fact that there is already twinned pipes in well maintained easements from Arva to Fanshawe Park Road.

Thank you.

Adams, Paul (London ON)

From:

Hi Jim,

The City owns the property in the parallelogram shape shown between lots 22 and 23. That being said, we are okay with the existing fence that it is currently on it and for you to enjoy that land space when the City doesn't need access. The pipe is currently in good condition, so no maintenance or repair work is anticipated anytime soon. Therefore, lets plan to touch base again in the spring and set up a meeting with you and your neighbors. At that time we can also evaluate if your existing gate is sufficient for access or if it should be extended at City cost. Also a reminder, that in the event the City does need to access the Chamber, any disturbances to your fence or lawn will be restored by City forces. Based on your email, it sounds like there aren't any man-made obstacles in your yard on the easement which is good, but we can confirm in the spring. A good practice going forward is to ensure that this space is kept as just grass and fencing.

Regards,

Stephen Romano, M.Eng, P.Eng
Environmental Services Engineer
Water Engineering Division
City of London

From: Jim J [mailto:jimjamesjacob@hotmail.com]

Sent: Tuesday, December 8, 2020 2:33 PM

To: Romano, Stephen <sromano@london.ca>

Cc: Adams, Paul (London ON) <Paul.Adams2@aecom.com>; Abou Taka, Bander <Bander.AbouTaka@aecom.com>; Haasen, John <John.Haasen@aecom.com>

Subject: [EXTERNAL] Re: Regarding Arva Pumping water main project | High risk area.

Good afternoon Stephen,

Hope you are doing well and it was nice speaking with you other day. That yellow line is something very new for me and just came to know after watching presentation on site.

City's lease agreement is 25 feet wide X 120 feet depth (unsure about depth, have to look up the doc but width is 25 feet - might be that rectangle plot only? Then it makes sense) Even though yellow line clears my house and garage, at backyard, the yellow line goes very closer to my shed and practically left with very less awkward shaped backyard ! This yellow line was not mentioned in deed, not anywhere in city docs, lawyer also told he checked it and couldn't find it - so wondering who owns that property ? Is it city or the home owner?

As you can imagine , as a new home owner I can only believe what real estate agent, lawyer tells and that yellow line wasn't mentioned anywhere. As a home owner, only silver-lining I could see is I am dealing with some kind hearted people who can understand my situation as well.

If there are any expansion plans or anything of that nature, kindly let us know and I will be happy to meet you and your team. If no changes in near future or not expecting to get any work maintenance work done within 3 months; we can meet at spring time too (So I can request my neighbours to join as well).

Thank you once again Stephen and please keep me

posted. Have a great day.

Regards,
Jim
Jacob.

From: Romano, Stephen <sromano@london.ca>

Hi Jim,

It was nice talking with you on the phone last week, and as promised we looked into more details on your property and adjacent properties which are subject to the easement. Please see below figure which highlights where our records shows the easement coordinates are. Please let me know if this aligns with your lease agreement (You are lot 23 in the below figure). The area highlighted in green is City of London owned property.

As mentioned, we are happy to meet you and/or your neighbors while abiding to COVID-19 protocols to look at your yards in more detail and discuss potential future steps. Just let me know a couple dates/times that would work for you and we will set something up if you would still like to pursue this.

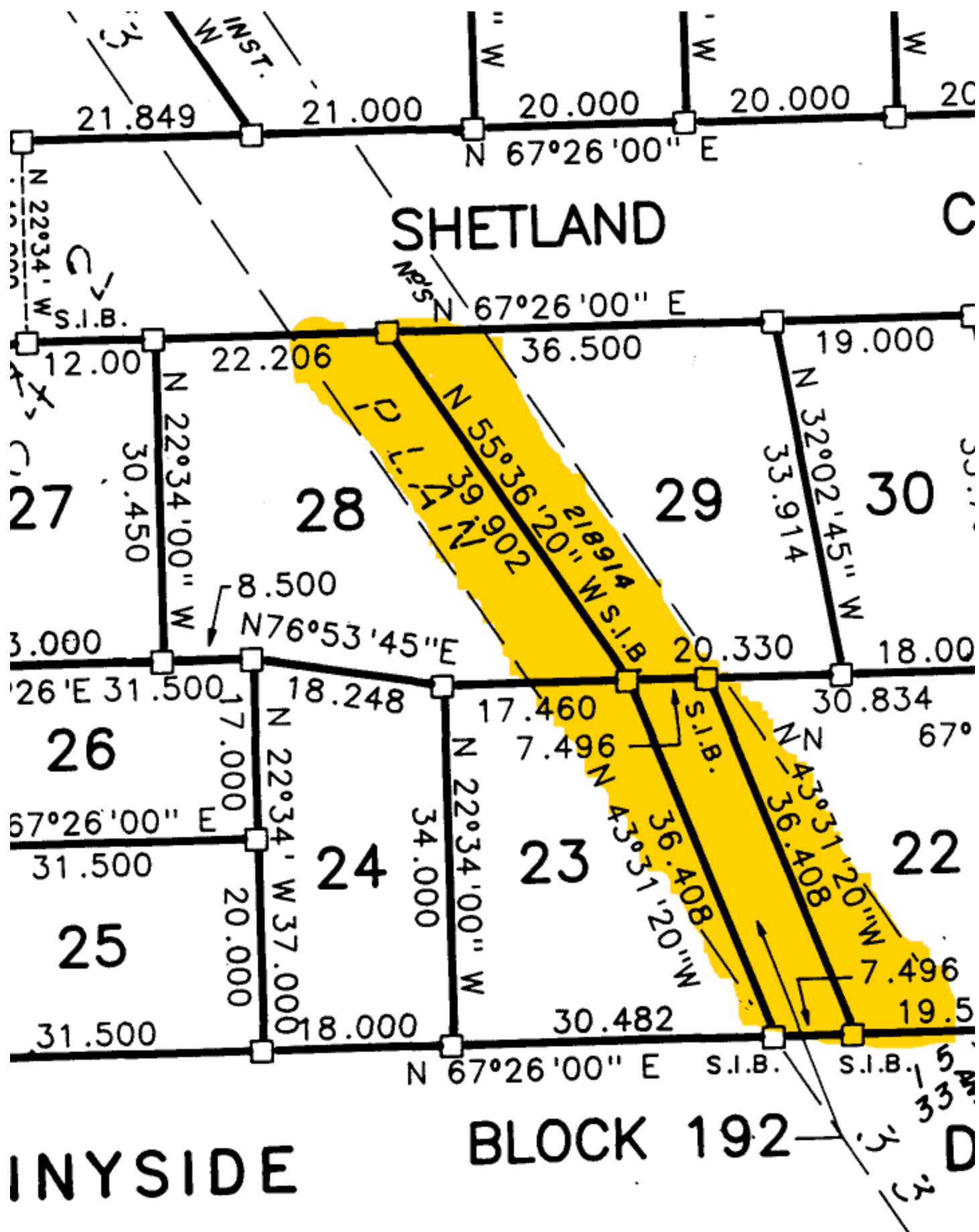

Adams, Paul (London ON)

From: Romano, Stephen <sromano@london.ca>
Sent: Monday, November 23, 2020 9:55 AM
To:
Cc: Adams, Paul (London ON)
Subject: [EXTERNAL] RE: Arva Huron Transmission Watermain Project

Hi Jack,

This project will not impact your enclave. The long-term re-routing of the watermain considers routes under the roadways on Richmond St or Adelaide St. You received the letter as your property borders on Richmond St.

Regards,

Stephen Romano, M.Eng,
P.Eng Environmental Services
Engineer Water Engineering
Division
City of London

-----Original Message-----

Subject: Re: [EXTERNAL] Arva Huron Transmission Watermain Project

Thanks Stephen, I currently live in Foxborough Chase and am interested in knowing if the watermain project will impact our enclave?

Thanks, Jack.

> On Nov 18, 2020, at 7:04 PM, Romano, Stephen <sromano@london.ca> wrote:

>

> Hi Jack,

> You have been added to the list.

> Regards,

>

> Stephen Romano, M.Eng, P.Eng

> Environmental Services Engineer

> Water Engineering Division

> City of London

>

>

> -----Original Message-----

> From: >

> Stephen, please place me on the mailing list for information and updates for this project. Thank you.

>

> Jack Santandrea
> 47 - 1890 Richmond Street
> London, Ont.
> N5X 4J2
>
> or e-mail kjsantandrea@hay.net
>
> Thank you.

Adams, Paul (London ON)

Hello Rod and Liz,

The watermain does not cross onto your property. You received the letter as you are within the study area and there may be construction on your street or adjacent streets to yours as a result of this project. The existing watermain actually runs down Maitland St (see highlighted area in figure below).

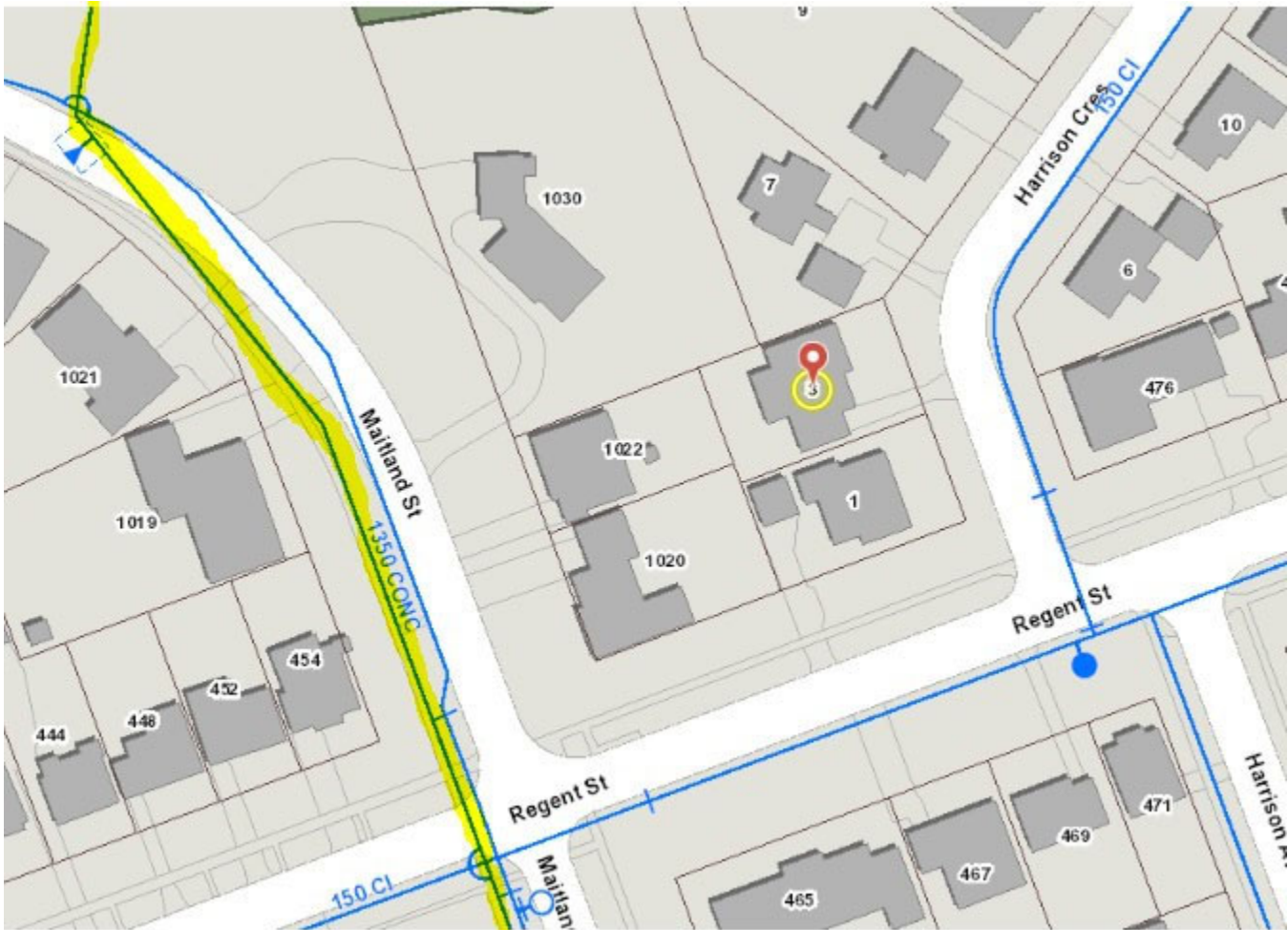

Hope this clarifies things for you and feel free to reach out if you have any additional questions.
Best Regards,

Stephen Romano, M.Eng, P.Eng
Environmental Services Engineer
Water Engineering Division
City of London

From: Rod and Liz Beaujot [mailto:beaujot.london@gmail.com]
Sent: Tuesday, November 17, 2020 3:01 PM
To: Romano, Stephen <sromano@london.ca>
Subject: [EXTERNAL] Arva to Huron St Watermain easement

Stephen Romano,

We have owned 3 Harrison Crescent, London, ON N5Y 2V3 for less than a year, so we were unaware that we are located so close to this watermain. Because it is difficult to see due to the size and darkness of the map, could you let us know exactly where the watermain passes in relation to our property line?

Many thanks,
Elisabeth and Roderic Beaujot